

Model 110B Compact Loudspeaker

For seamless background music & clear voice announcements

The Soundsphere Model 110B loudspeaker was designed to provide clear voice announcements, seamless background music and even, omnidirectional coverage. The Model 110B is a compact, unobtrusive speaker that is just 10" in diameter and offers fast distributed system installation. Applications include retail stores; factories and warehouses; mass transportation centers; restaurants; and stadium and arena concourses, gift shops and rest rooms.

The 110B comes fully assembled, and its light weight allows many mounting possibilities, using either our hanging kit or mounting bracket. Both standard and custom colors are available.

110B Technical Data

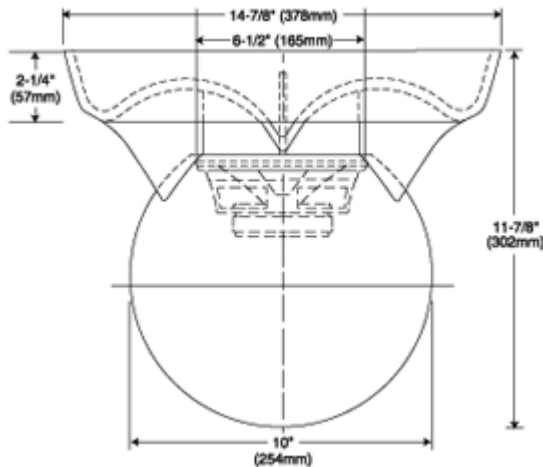

MODEL 110B APPLICATIONS:	
• Supermarkets & Retail Stores	
• Factories	
• Warehouses	
• Courtrooms	
• Classrooms & Other Educational Facilities	
• Stadium or Arena Concourses, Gift Shops & Rest Rooms	
• Airports & Transportation Centers	
• Office Building Reception Areas	
• Restaurants	
• Casinos	
• Shopping Center Common Areas & Food Courts	
<i>And anywhere background music and articulate voice announcements are required.</i>	

MODEL 110B SPECIFICATIONS:	
Sensitivity:	96dB SPL; 1W/1m
Maximum SPL:	111dB SPL; 30W/1m
Power Handling:	35 Watts
Frequency Response:	150Hz to 12kHz ± 6dB
Coverage:	180° vertical 360° horizontal
Rated Impedance:	4 ohms
Weight:	8 lbs. (3.6 kg)
Size:	Height: 11-7/8" (302mm) Sphere Diameter: 10" (254mm) Reflector Diameter: 14-7/8" (378mm)
Driver:	Dual Cone 6-1/2"

Material:	Enclosure and reflector are structural foam polystyrene with rustproof hardware
MODEL 110B SAMPLE INSTALLATIONS:	
Retail Store	
Automobile Dealership Showroom	
Shopping Mall	
Factory	

Model 110B Accessories

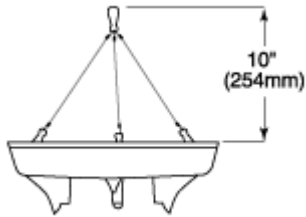

Hanging Kit – Order No. HK

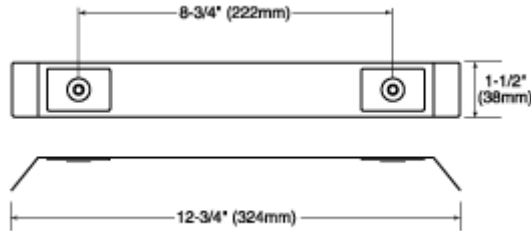

Mounting Bracket – Order No. MBS
for mounting speaker on a flat surface



Beam Clip – Order No. BC
Locates a 1/4" hole on a 1/8" to 1/4" beam flange using just a

hammer.



Drop Ceiling Bracket – Order No. DCB
Two twist clips and 110MB are supplied. Clips twist onto t-bar stringers, and mounting bracket attaches with wing nuts.

Line Matching Transformer — Order No. TX30

The Model TX30 is a 30 Watt line matching transformer for the Model 110B with taps for 25, 50, 70, and 100 Volt constant voltage systems. The TX30 is designed for factory or field mounting in the 110B reflector. Connection to system wiring is via 10" color coded flying leads. Available taps: 25 Volt: 30, 15, 7.5, 3.8, 1.9, 1.0, 0.5 Watts; 50 Volt: 30, 15, 7.5, 3.8, 1.9 Watts; 70 Volt: 30, 15, 7.5, 3.8 Watts; 100 Volt: 30, 15, 7.5 Watts.